

The Digital-to-Analogue Conversions (DAC) and Analogue-to-Digital Conversion (ADC)

Slide 1

Digital to Analogue Conversion

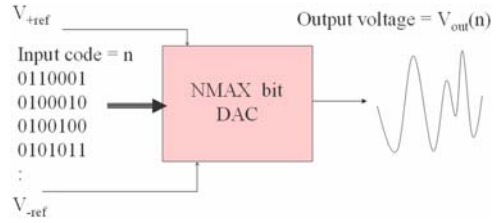

Slide 2

Digital to Analogue Conversion

- V_{+ref} , V_{-ref} are the high, low reference voltages respectively, NMAX=bit length of the DAC, n is the input code.

$$V_{out}(n) = V_{-ref} + n \left[\frac{V_{+ref} - V_{-ref}}{2^{NMAX}} \right]$$

$$= V_{-ref} + n \Delta V$$

- At $n=0$, $V_{out}(0) = V_{-ref}$
- At max. $n=2^{NMAX} - 1$, V_{out} cannot reach V_{+ref} , (e.g., for NMAX= 4, $n=0,1,2,...15$)
- Some DACs have internal reference voltage settings, some can be set externally.

Slide 3

The DAC0830

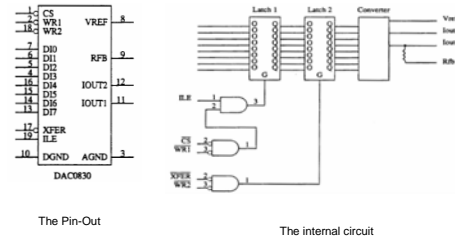

The Pin-Out

The internal circuit

Slide 4

The DAC0830 Interface to the Microprocessor

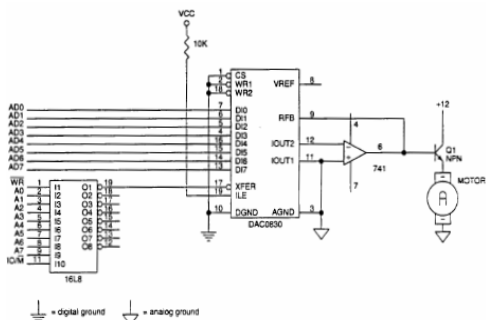

Slide 5

Analogue to Digital Conversion

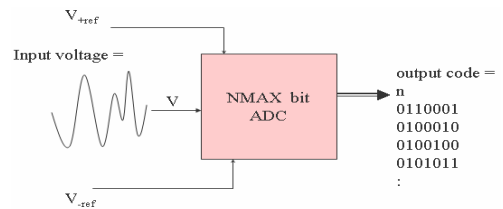

Slide 6

Analogue to Digital Conversion

● n = converted code, V = input voltage,

$$n = \left[\frac{V - V_{-ref}}{\Delta V} + \frac{1}{2} \right]_{\text{integer}}, \text{ where } \Delta V = \frac{V_{+ref} - V_{-ref}}{2^N - 1},$$

e.g., $V_{-ref} = 0$, $\Delta V = 10 \text{ mV}$, as shown below :

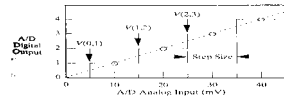

Slide 7

The ADC0804

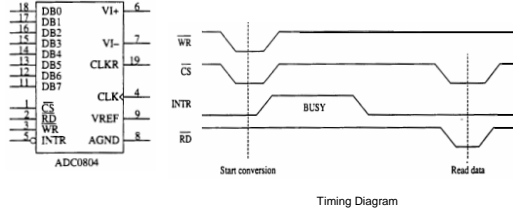

Slide 8

The Analogue Input to the ADC0804



(a) To sense a 0- to +5.0-V input.



(b) To sense an input offset from ground.

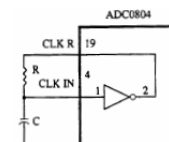

Connecting the RC circuit to the CLK IN and CLK R pins on the ADC0804.

$$F_{clk} = \frac{1}{1.1 RC}$$

Slide 9

The Analogue Interface to the Microprocessor

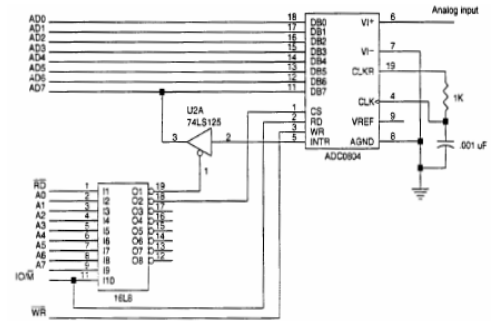

Slide 10

Application Example

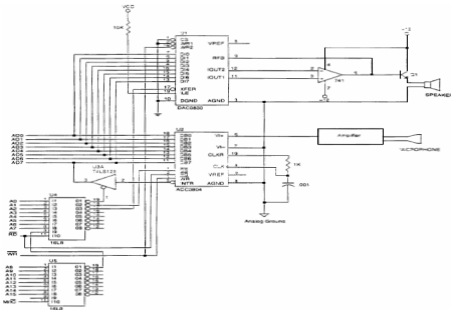

Slide 11